

# Solitary waves in massive non-linear $\mathbb{S}^2$ -sigma and $\mathbb{S}^3$ -sigma models

A. Alonso Izquierdo, M.A. González León and M. de la Torre Mayado

Eighth International Conference:  
“Symmetry in Nonlinear Mathematical Physics”

Kyiv, June 2009

# 1 Introduction

Let  $\phi_1(y^0, y^1), \dots, \phi_n(y^0, y^1)$  be  $n$  scalar fields arranged in a vector field:

$$\vec{\Phi} \in \text{Maps}(\mathbb{R}^{1,1}, \mathbb{S}^{n-1}), \quad \vec{\Phi}(t, x) = (\phi_1(t, x), \dots, \phi_n(t, x))$$

$$\vec{\Phi} \cdot \vec{\Phi} = \phi_1^2 + \dots + \phi_n^2 = R^2$$

The action governing the dynamics of the model is:

$$S[\vec{\Phi}] = \int dy^0 dy^1 \mathcal{L}(\partial_\mu \vec{\Phi}, \vec{\Phi}) = \int dy^0 dy^1 \left\{ \frac{1}{2} \partial_\mu \vec{\Phi} \cdot \partial^\mu \vec{\Phi} - V(\vec{\Phi}) \right\} \quad (1)$$

$$t \equiv y^0, \quad x \equiv y^1, \quad y^\mu \cdot y_\mu = g^{\mu\nu} y_\mu y_\nu, \quad g^{\mu\nu} = \text{diag}(1, -1), \quad \partial_\mu \partial^\mu = g^{\mu\nu} \partial_\mu \partial_\nu = \partial_t^2 - \partial_x^2$$

The potential energy density is very simple, only containing quadratic terms in an anisotropic way:

$$V(\vec{\Phi}) = \frac{1}{2} (\alpha_1^2 \phi_1^2 + \alpha_2^2 \phi_2^2 + \dots + \alpha_n^2 \phi_n^2) \quad (2)$$

$$\alpha_1^2 > \alpha_2^2 > \dots > \alpha_n^2 \geq 0 \quad (3)$$

Let us arrange the potential term in such a way that absolute minima (a set,  $\mathcal{M}$ , of isolated points) coincide with the zeroes of  $V$ .

$$V(\phi_1, \dots, \phi_n) = \frac{1}{2} (\alpha_1^2 \phi_1^2 + \dots + \alpha_n^2 \phi_n^2 - \alpha_n^2 R^2) \quad (4)$$

$\mathcal{M}$  is:

$$\mathcal{M} = \{v^+ = (0, \dots, 0, R), \quad v^- = (0, \dots, 0, -R)\} \quad (5)$$

Field equations:

$$\partial_\mu \left( \frac{\partial \mathcal{L}}{\partial (\partial_\mu \phi_j)} \right) - \frac{\partial \mathcal{L}}{\partial \phi_j} = 0 \Rightarrow \partial_t^2 \phi_j - \partial_x^2 \phi_j = -\alpha_j^2 \phi_j \quad (6)$$

constrained to the  $\mathbb{S}^{n-1}$ -sphere.

$$S[\phi] = \int dt \left\{ \int dx \frac{1}{2} \partial_t \vec{\Phi} \cdot \partial_t \vec{\Phi} - \int dx \left( \frac{1}{2} \partial_x \vec{\Phi} \cdot \partial_x \vec{\Phi} + V(\vec{\Phi}) \right) \right\}$$

Energy Functional:

$$E[\phi] = \int dt \left\{ \int dx \frac{1}{2} \partial_t \vec{\Phi} \cdot \partial_t \vec{\Phi} + \int dx \left( \frac{1}{2} \partial_x \vec{\Phi} \cdot \partial_x \vec{\Phi} + V(\vec{\Phi}) \right) \right\} \quad (7)$$

$$E[\phi] = \int dt dx \varepsilon(x, t) \quad (8)$$

Simplest solutions of the field equations:

Homogeneous and static solutions (i.e.  $t$ -independent and  $x$ -independent): Absolute Minima of  $V(\vec{\Phi}) \equiv \mathcal{M}$

Solitary Waves (Kinks): Non-singular solutions of the field equations of finite energy such that their energy density has a space-time dependence of the form  $\varepsilon(x, t) = \varepsilon(x - vt)$  where  $v$  is some velocity vector.

Lorentz-invariance  $\Rightarrow$  It is sufficient to know the  $t$ -independent (static) solutions in order to obtain all the solitary waves of the model.

Reduction to static solutions:  $\vec{\Phi} = \vec{\Phi}(x)$ :

$$\frac{d^2 \phi_j}{dx^2} = \alpha_j^2 \phi_j \quad , \quad \phi_1^2 + \dots + \phi_n^2 = R^2 \quad (9)$$

$$E[\phi] = \int dx \left( \frac{1}{2} \frac{d\vec{\Phi}}{dx} \cdot \frac{d\vec{\Phi}}{dx} + V(\vec{\Phi}) \right) = \int dx \varepsilon(x)$$

Finite Energy  $\Rightarrow$  Asymptotic conditions:

$$\lim_{x \rightarrow \pm\infty} \frac{d\vec{\Phi}}{dx} = 0 \quad , \quad \lim_{x \rightarrow \pm\infty} \vec{\Phi} \in \mathcal{M} \quad (10)$$

The configuration space  $\mathcal{C} = \{ \text{Maps}(\mathbb{R}, \mathbb{S}^{n-1}) / E < +\infty \}$  of solitary waves is the union of four disconnected sectors

$$\mathcal{C} = \mathcal{C}_{\text{NN}} \cup \mathcal{C}_{\text{SS}} \cup \mathcal{C}_{\text{NS}} \cup \mathcal{C}_{\text{SN}}$$

where  $v^+ \equiv N$ ,  $v^- \equiv S$ , and the different sectors are labeled by the element of  $\mathcal{M}$  reached by each configuration at the two disconnected components of the boundary of the real line.

$\mathcal{C}_{NS}$  and  $\mathcal{C}_{SN}$  solitary waves are called [Topological Kinks](#).

$\mathcal{C}_{NN}$  and  $\mathcal{C}_{SS}$  solitary waves are called [Non-Topological Kinks](#).

The mathematical problem is to solve equations:

$$\frac{d^2\phi_j}{dx^2} = \alpha_j^2 \phi_j \quad , \quad j = 1, \dots, n \quad (11)$$

constrained to:

$$\phi_1^2 + \dots + \phi_n^2 = R^2$$

and verifying the asymptotic conditions:

$$\lim_{x \rightarrow \pm\infty} \frac{d\phi_j}{dx} = 0 \quad , \quad j = 1, \dots, n \quad (12)$$

$$\lim_{x \rightarrow \pm\infty} \phi_i = 0, \quad i = 1, \dots, n-1. \quad \lim_{x \rightarrow \pm\infty} \phi_n = \pm R \quad (13)$$

## 2 The nonlinear $\mathbb{S}^2$ - sigma model

$$\vec{\Phi} = (\phi_1, \phi_2, \phi_3) \quad , \quad \phi_1^2 + \phi_2^2 + \phi_3^2 = R^2 \quad (14)$$

$$V(\phi_1, \phi_2, \phi_3) = \frac{1}{2} (\alpha_1^2 \phi_1^2 + \alpha_2^2 \phi_2^2 + \alpha_3^2 \phi_3^2) \quad , \quad \alpha_1^2 \geq \alpha_2^2 > \alpha_3^2 \geq 0 \quad (15)$$

$\mathcal{M} : \phi_1^{v^\pm} = \phi_2^{v^\pm} = 0, \phi_3^{v^\pm} = \pm R$  (North and South Poles of  $\mathbb{S}^2$ )

### Resolution

Solving  $\phi_3$  in favor of  $\phi_1$  and  $\phi_2$ :

$$\phi_3 = \text{sg}(\phi_3) \sqrt{R^2 - \phi_1^2 - \phi_2^2}$$

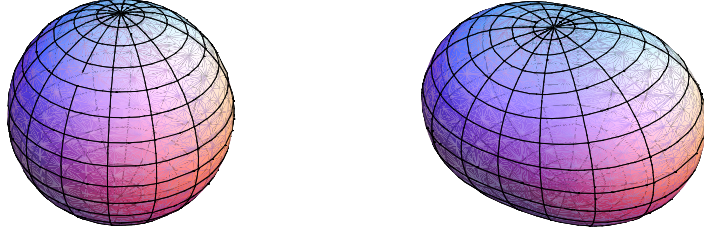

$$S = \frac{1}{2} \int dt dx \left\{ \partial_\mu \phi_1 \partial^\mu \phi_1 + \partial_\mu \phi_2 \partial^\mu \phi_2 + \frac{(\phi_1 \partial_\mu \phi_1 + \phi_2 \partial_\mu \phi_2)(\phi_1 \partial^\mu \phi_1 + \phi_2 \partial^\mu \phi_2)}{R^2 - \phi_1^2 - \phi_2^2} - V_{\mathbb{S}^2}(\phi_1, \phi_2) \right\}$$

$$V_{\mathbb{S}^2}(\phi_1, \phi_2) = \frac{1}{2} ((\alpha_1^2 - \alpha_3^2) \phi_1^2 + (\alpha_2^2 - \alpha_3^2) \phi_2^2 + \text{const.}) \simeq \frac{\lambda^2}{2} \phi_1^2(t, x) + \frac{\gamma^2}{2} \phi_2^2(t, x) \quad (16)$$

$$\lambda^2 = (\alpha_1^2 - \alpha_3^2), \quad \gamma^2 = (\alpha_2^2 - \alpha_3^2), \quad \lambda^2 \geq \gamma^2$$



Non-dimensionalization: Taking into account that in the natural system of units  $\hbar = c = 1$  the dimensions of fields, masses and coupling constants are  $[\phi_a] = 1 = [R]$ ,  $[\gamma] = M = [\lambda]$

Non-dimensional space-time coordinates and masses

$$x^\mu \rightarrow \frac{x^\mu}{\lambda}, \quad \sigma^2 = \frac{\alpha_2^2 - \alpha_3^2}{\alpha_1^2 - \alpha_3^2} = \frac{\gamma^2}{\lambda^2}, \quad 0 < \sigma^2 \leq 1,$$

$$E = \frac{\lambda}{2} \int dx \left\{ (\partial_t \phi_1)^2 + (\partial_t \phi_2)^2 + (\partial_x \phi_1)^2 + (\partial_x \phi_2)^2 + \frac{(\phi_1 \partial_t \phi_1 + \phi_2 \partial_t \phi_2)^2 + (\phi_1 \partial_x \phi_1 + \phi_2 \partial_x \phi_2)^2}{R^2 - \phi_1^2 - \phi_2^2} + \right. \\ \left. + \phi_1^2(t, x) + \sigma^2 \phi_2^2(t, x) \right\} \quad (17)$$

Thus we can study the equations depending in only one significative constant,  $\sigma$ .

Using Spherical coordinates. “Special” solitary waves solutions

Solving the constraint by using spherical coordinates:  $\theta \in [0, \pi]$ ,  $\varphi \in [0, 2\pi)$

$$\phi_1(t, x) = R \sin \theta(t, x) \cos \varphi(t, x)$$

$$\phi_2(t, x) = R \sin \theta(t, x) \sin \varphi(t, x)$$

$$\phi_3(t, x) = R \cos \theta(t, x)$$

$$V(\theta, \varphi) = \frac{R^2}{2} \sin^2 \theta (\sigma^2 + \bar{\sigma}^2 \cos^2 \varphi) \quad , \quad \bar{\sigma} = \sqrt{1 - \sigma^2} \quad (18)$$

$$S = \int dt dx \left\{ \frac{R^2}{2} [\partial_\mu \theta \partial^\mu \theta + \sin^2 \theta \partial_\mu \varphi \partial^\mu \varphi] - \frac{R^2}{2} \sin^2 \theta (\sigma^2 + \bar{\sigma}^2 \cos^2 \varphi) \right\} \quad (19)$$

Field equations:

$$\square \theta - \frac{1}{2} \sin 2\theta (\partial^\mu \varphi \partial_\mu \varphi - \cos^2 \varphi - \sigma^2 \sin^2 \varphi) = 0 \quad (20)$$

$$\partial^\mu (\sin^2 \theta \partial_\mu \varphi) - \frac{1}{2} \bar{\sigma}^2 \sin^2 \theta \sin 2\varphi = 0 \quad (21)$$

Static field equations:

$$\theta'' - \frac{1}{2} \sin 2\theta (\varphi')^2 = \frac{1}{2} (\cos^2 \varphi + \sigma^2 \sin^2 \varphi) \sin 2\theta \quad (22)$$

$$\frac{d}{dx}(\sin^2 \theta \varphi') = \frac{1}{2} \bar{\sigma}^2 \sin^2 \theta \sin 2\varphi \quad (23)$$

$$\theta' = \frac{d\theta}{dx} \quad , \quad \varphi' = \frac{d\varphi}{dx}$$

The energy of the static configurations is:

$$E[\theta, \phi] = \lambda \int dx \mathcal{E}(\theta'(x), \varphi'(x), \theta(x), \varphi(x)) \quad (24)$$

$$\mathcal{E} = \frac{\lambda R^2}{2} ((\theta')^2 + \sin^2 \theta (\varphi')^2 + \sin^2 \theta (\sigma^2 + \bar{\sigma}^2 \cos^2 \varphi)) \quad (25)$$

## Topological kinks

Field equation (23) is satisfied for constant values of  $\varphi$  if and only if:

$$\varphi = 0, \frac{\pi}{2}, \pi, \frac{3\pi}{2}$$

Depending on which pair of  $\varphi$ -constant solution we choose, equation (20) becomes one or another sine-Gordon equation:

$$\square\theta + \frac{\sigma^2}{2} \sin 2\theta = 0 ; \quad \square\theta + \frac{1}{2} \sin 2\theta = 0$$

Thus, sine-Gordon models are embedded in the system on these two orthogonal meridians.

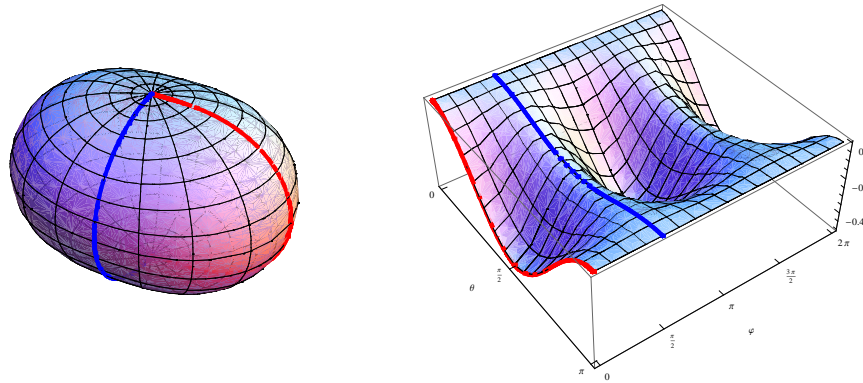

### ***K1* Kinks**

**$K_1/K_1^*$  kinks.** We denote  $K_1/K_1^*$  the kink/antikink solutions of the sG model embedded inside the  $\mathbb{S}^2$  model in the  $\varphi_{K_1}(x) = \frac{\pi}{2}$  or  $\varphi_{K_1^*}(x) = \frac{3\pi}{2}$  two halves of the single meridian intersecting the  $\phi_2 : \phi_3$  plane,

$$\varphi_{K_1}(x) = \frac{\pi}{2}, \quad \varphi_{K_1^*}(x) = \frac{3\pi}{2} \quad ; \quad \theta_{K_1}(x) = \theta_{K_1^*}(x) = 2 \arctan e^{\pm\sigma(x-x_0)} \quad (26)$$

The energy of these kinks, which belong to  $\mathcal{C}_{\text{NS}}$  (kinks) or  $\mathcal{C}_{\text{SN}}$  (antikinks), is:

$$E_{K_1} = E_{K_1^*} = 2\lambda R^2 \sigma$$

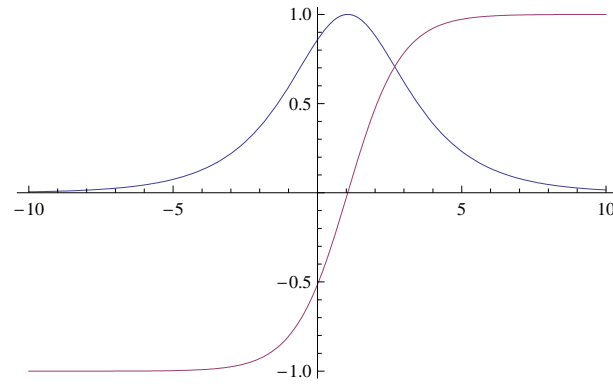

## $K_2$ Kinks

**$K_2/K_2^*$  kinks.** Taking  $\varphi_{K_2}(x) = 0$  or  $\varphi_{K_2^*}(x) = \pi$ , we find the sG kinks:

$$\varphi_{K_2}(x) = 0, \quad \varphi_{K_2^*}(x) = \pi \quad ; \quad \theta_{K_2}(x) = \theta_{K_2^*}(x) = 2 \arctan e^{\pm(x-x_0)} . \quad (27)$$

The energy of the  $K_2/K_2^*$  kinks, which also belong to the  $\mathcal{C}_{\text{NS}}$ ,  $\mathcal{C}_{\text{SN}}$  sectors, is greater than the energy of the  $K_1/K_1^*$  kinks:

$$E_{K_2} = E_{K_2^*} = 2\lambda R^2$$

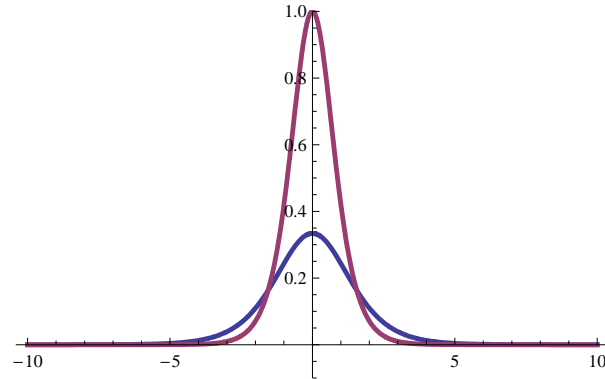

## Application

The static field equations of this massive non-linear sigma model can be interpreted as the static Landau-Lifshitz equations governing the high spin and long wavelength limit of  $1D$  ferromagnetic materials.

From this perspective, topological kinks can be interpreted respectively as Bloch and Ising walls that form interfaces between ferromagnetic domains

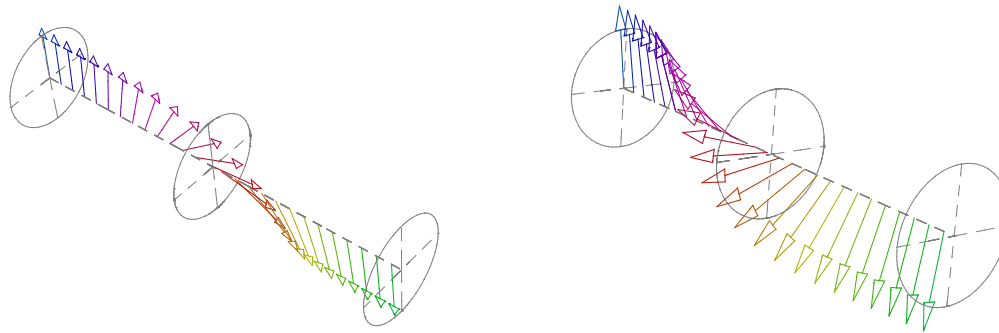

Using Conical Coordinates. “Generic” solitary waves.

$$V_{\mathbb{S}^2}(\phi_1, \phi_2, \phi_3) = \frac{1}{2} (\alpha_1^2 \phi_1^2 + \alpha_2^2 \phi_2^2 + \alpha_3^2 \phi_3^2) \cong \frac{1}{2} (\phi_1^2 + \sigma^2 \phi_2^2) \quad (28)$$

$$\phi_1^2 + \phi_2^2 + \phi_3^2 = R^2$$

(Neumann potential in  $\mathbb{S}^2$ ).

$$\begin{aligned} \phi_1^2 &= \frac{\lambda_0}{\sigma^2} \lambda_1 \lambda_2 \\ \phi_2^2 &= \frac{\lambda_0}{\sigma^2 \bar{\sigma}^2} (\bar{\sigma}^2 - \lambda_1)(\lambda_2 - \bar{\sigma}^2) \\ \phi_3^2 &= \frac{\lambda_0}{\sigma^2} (1 - \lambda_1)(1 - \lambda_2) \end{aligned} \quad (29)$$

with:

$$0 < \lambda_1 < \bar{\sigma}^2 < \lambda_2 < 1$$

$\bar{\sigma}^2 = 1 - \sigma^2$ . These inequalities define the interior of the rectangle  $\mathbb{P}_2$ .

Constraint-equation for  $\mathbb{S}^2$  reduces to:

$$\phi_1^2 + \phi_2^2 + \phi_3^2 = R^2 \Rightarrow \lambda_0 = R^2$$



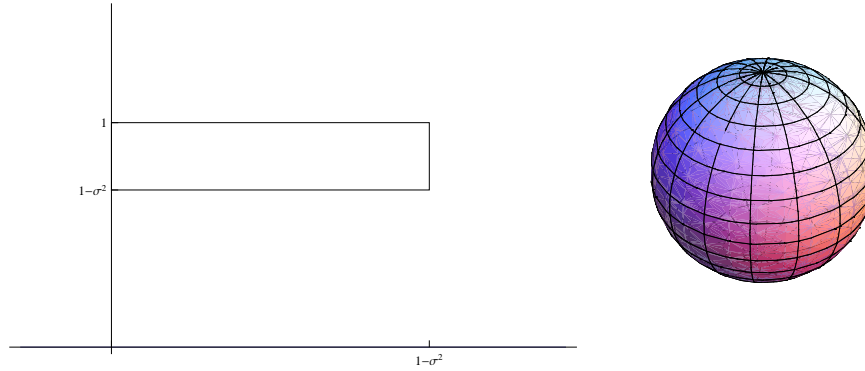

$\mathcal{M}$ :

$$v^\pm \equiv (\phi_1, \phi_2, \phi_3) = (0, 0, \pm R) \Rightarrow v^\pm \equiv (\lambda_1, \lambda_2) = (0, \bar{\sigma}^2)$$

(only a point in  $\mathbb{P}_2$ ).

$$V_{\mathbb{S}^2}(\lambda_1, \lambda_2) = -\frac{\lambda_0}{2} (\lambda_1 + \lambda_2 - \bar{\sigma}^2) \quad (30)$$

$$E[\lambda_1, \lambda_2] = \lambda \int dx \left\{ \frac{1}{2} \bar{g}_{11} \left( \frac{d\lambda_1}{dx} \right)^2 + \frac{1}{2} \bar{g}_{22} \left( \frac{d\lambda_2}{dx} \right)^2 + \frac{\lambda_0}{2} \left( \frac{\lambda_1 (\lambda_1 - \bar{\sigma}^2)}{\lambda_1 - \lambda_2} + \frac{\lambda_2 (\lambda_2 - \bar{\sigma}^2)}{\lambda_2 - \lambda_1} \right) \right\} \quad (31)$$

$$\bar{g}_{11} = \frac{-\lambda_0(\lambda_1 - \lambda_2)}{4\lambda_1(\bar{\sigma}^2 - \lambda_1)(1 - \lambda_1)}, \quad \bar{g}_{22} = \frac{-\lambda_0(\lambda_2 - \lambda_1)}{4\lambda_2(\bar{\sigma}^2 - \lambda_2)(1 - \lambda_2)}$$

Bogomol'nyi form:

$$E[\lambda_1, \lambda_2] = \lambda \int \frac{dx}{2} \left\{ \sum_{i=1}^2 g_{ii} \left( \frac{d\lambda_i}{dx} + g^{ii} \frac{\partial W}{\partial \lambda_i} \right)^2 \right\} + \lambda \int dx \sum_{j=1}^2 \frac{\partial W}{\partial \lambda_j} \frac{d\lambda_j}{dx} \quad (32)$$

where  $W$  is a solution of the PDE:

$$\frac{\lambda_0}{2} \left( \frac{\lambda_1(\lambda_1 - \bar{\sigma}^2)}{\lambda_1 - \lambda_2} + \frac{\lambda_2(\lambda_2 - \bar{\sigma}^2)}{\lambda_2 - \lambda_1} \right) = \frac{1}{2} \left( \bar{g}^{11} \left( \frac{\partial W}{\partial \lambda_1} \right)^2 + \bar{g}^{22} \left( \frac{\partial W}{\partial \lambda_2} \right)^2 \right) \quad (33)$$

i.e.  $W$  is the zero-energy reduced-characteristic Hamilton function. (Note that (33) is nothing but the reduced Hamilton-Jacobi equation (with zero mechanical energy) of the “repulsive” Neumann problem).

Ansatz:  $W(\lambda_1, \lambda_2) = W_1(\lambda_1) + W_2(\lambda_2)$

$$\frac{dW_1}{d\lambda_1} = \frac{-\lambda_0}{2} (-1)^a \frac{1}{\sqrt{1 - \lambda_1}}$$

$$\frac{dW_2}{d\lambda_2} = \frac{-\lambda_0}{2} (-1)^b \frac{1}{\sqrt{1-\lambda_2}}$$

$a, b = 0, 1.$

$$W(\lambda_1, \lambda_2) = \lambda_0 \left( (-1)^a \sqrt{1-\lambda_1} + (-1)^b \sqrt{1-\lambda_2} \right) \quad (34)$$

First order equations:

$$\frac{d\lambda_1}{dx} = (-1)^a \frac{2\lambda_1 (\lambda_1 - \bar{\sigma}^2) \sqrt{1-\lambda_1}}{(\lambda_1 - \lambda_2)} \quad (35)$$

$$\frac{d\lambda_2}{dx} = (-1)^b \frac{2\lambda_2 (\lambda_2 - \bar{\sigma}^2) \sqrt{1-\lambda_2}}{(\lambda_2 - \lambda_1)} \quad (36)$$

$$\frac{\frac{d\lambda_1}{dx}}{(-1)^a 2\lambda_1 (\lambda_1 - \bar{\sigma}^2) \sqrt{1-\lambda_1}} = \frac{dx}{(\lambda_1 - \lambda_2)}$$

$$\frac{\frac{d\lambda_2}{dx}}{(-1)^b 2\lambda_2 (\lambda_2 - \bar{\sigma}^2) \sqrt{1-\lambda_2}} = \frac{dx}{(\lambda_2 - \lambda_1)}$$

$$\frac{d\lambda_1}{(-1)^a 2\lambda_1 (\lambda_1 - \bar{\sigma}^2) \sqrt{1-\lambda_1}} + \frac{d\lambda_2}{(-1)^b 2\lambda_2 (\lambda_2 - \bar{\sigma}^2) \sqrt{1-\lambda_2}} = 0 \quad (37)$$

$$\frac{d\lambda_1}{(-1)^a 2(\lambda_1 - \bar{\sigma}^2)\sqrt{1 - \lambda_1}} + \frac{d\lambda_2}{(-1)^b 2(\lambda_2 - \bar{\sigma}^2)\sqrt{1 - \lambda_2}} = dx \quad (38)$$

$$\lambda_1(x) = 1 - \left( \frac{\bar{\sigma}^2 t_1}{2(1 - \sigma t_1 t_2)} + \frac{1}{2} \sqrt{\frac{\bar{\sigma}^4 t_1^2 + 4\sigma^2 - 4\sigma t_1 t_2(1 + \sigma^2 - \sigma t_1 t_2)}{(1 - \sigma t_1 t_2)^2}} \right)^2 \quad (39)$$

$$\lambda_2(x) = 1 - \left( \frac{\bar{\sigma}^2 t_1}{2(1 - \sigma t_1 t_2)} - \frac{1}{2} \sqrt{\frac{\bar{\sigma}^4 t_1^2 + 4\sigma^2 - 4\sigma t_1 t_2(1 + \sigma^2 - \sigma t_1 t_2)}{(1 - \sigma t_1 t_2)^2}} \right)^2 \quad (40)$$

where:

$$t_1 = \tanh((x + \gamma_1)), \quad t_2 = \tanh((x + \gamma_2))$$

It is easy to re-define the constants  $(\gamma_1, \gamma_2) \rightarrow (\gamma, \bar{\gamma})$  in such a way that  $\gamma$  characterizes the “center” of the energy density, whereas  $\bar{\gamma}$  determines the concrete orbit.

$$E_{NTK} = E_{K_1} + E_{K_2}$$

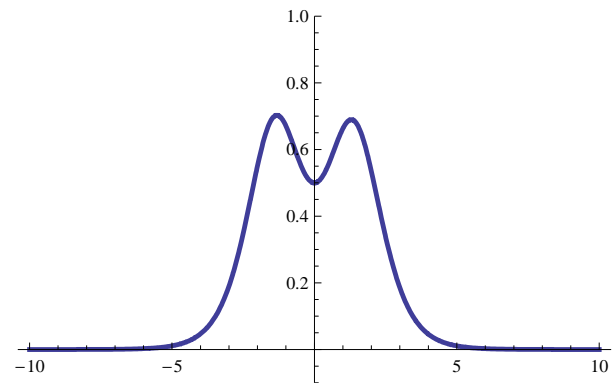
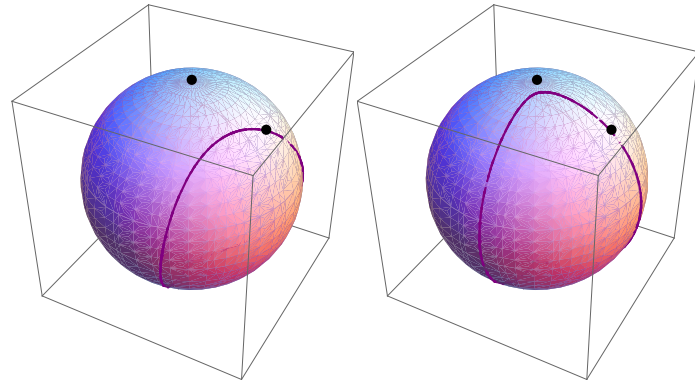

## Kink stability

### Small fluctuations on topological kinks, $K1$ and $K2$

The analysis of small fluctuations around kinks is determined by the second-order operator:

$$\Delta_K \eta = - \left( \nabla_{\theta'_K} \nabla_{\theta'_K} \eta + R(\theta'_K, \eta) \theta'_K + \nabla_{\eta} \text{grad} V \right) \quad (41)$$

where:

$$\theta = \theta^1 \in [0, \pi] \quad , \quad \varphi = \theta^2 \in [0, 2\pi) \quad ; \quad ds^2 = R^2 d\theta^1 d\theta^1 + R^2 \sin^2 \theta^1 d\theta^2 d\theta^2$$

$$\Gamma_{22}^1 = -\frac{1}{2} \sin 2\theta^1, \quad \Gamma_{12}^2 = \Gamma_{21}^2 = \cotan \theta^1 \quad , \quad R_{212}^1 = -R_{122}^1 = \sin^2 \theta^1, \quad R_{121}^2 = -R_{211}^2 = 1 \quad (42)$$

Kink trajectories and small deformations around them:

$$\theta_K(x) = (\theta_K^1(x) = \bar{\theta}, \theta_K^2(x) = \bar{\varphi}) \quad ; \quad \theta(x) = \theta_K(x) + \eta(x) \quad , \quad \eta(x) = (\eta^1(x), \eta^2(x))$$

Let us consider the following contra-variant vector fields along the kink trajectory,  $\eta, \theta'_K \in \Gamma(T\mathbb{S}^2|_K)$ :

$$\eta(x) = \eta^1(x) \frac{\partial}{\partial \theta^1} + \eta^2(x) \frac{\partial}{\partial \theta^2} \quad , \quad \theta'_K(x) = \bar{\theta}' \frac{\partial}{\partial \theta^1} + \bar{\varphi}' \frac{\partial}{\partial \theta^2}$$

The covariant derivative of  $\eta(x)$  and the action of the curvature tensor on  $\eta(x)$  are:

$$\nabla_{\theta'_K} \eta = (\eta'^i(x) + \Gamma_{jk}^i \eta^j \bar{\theta}'^k) \frac{\partial}{\partial \theta^i} \quad , \quad R(\theta'_K, \eta) \theta'_K = \bar{\theta}'^i \eta^j(x) \bar{\theta}'^k R_{ijk}^l \frac{\partial}{\partial \theta^l}.$$

Geodesic deviation operator:

$$\frac{D^2 \eta}{dx^2} + R(\theta'_K, \eta) \theta'_K = \nabla_{\theta'_K} \nabla_{\theta'_K} \eta + R(\theta'_K, \eta) \theta'_K .$$

Hessian of the potential:

$$\nabla_{\eta} \text{grad} V = \eta^i \left( \frac{\partial^2 V}{\partial \theta^i \partial \theta^j} - \Gamma_{ij}^k \frac{\partial V}{\partial \theta^k} \right) g^{jl} \frac{\partial}{\partial \theta^l}$$

evaluated at  $\theta_K(x)$ . In sum, second-order kink fluctuations are determined by the operator:

$$\Delta_K \eta = - \left( \nabla_{\theta'_K} \nabla_{\theta'_K} \eta + R(\theta'_K, \eta) \theta'_K + \nabla_{\eta} \text{grad} V \right)$$

$$\begin{aligned}
\Delta_K \eta = & - \left[ \frac{D^2 \eta}{dx^2} + R(\theta'_K, \eta) \theta'_K + \nabla_\eta \text{grad} V \right] = \\
& - \left( \frac{d^2 \eta^1}{dx^2} - \cos 2\bar{\theta} [\bar{\varphi}'^2 + \sigma^2 + \bar{\sigma}^2 \cos^2 \bar{\varphi}] \eta^1 - \sin 2\bar{\theta} \bar{\varphi}' \frac{d\eta^2}{dx} \right. \\
& - \left. [(1 + \cos 2\bar{\theta}) \bar{\varphi}' \bar{\theta}' + \frac{\sin 2\bar{\theta}}{2} (\bar{\varphi}'' - \bar{\sigma}^2 \frac{\sin 2\bar{\varphi}}{2})] \eta^2 \right) \frac{\partial}{\partial \theta^1} \\
& - \left( 2 \cotan \bar{\theta} \bar{\varphi}' \frac{d\eta^1}{dx} + (\cotan \bar{\theta} \bar{\varphi}'' - \bar{\varphi}' \bar{\theta}') \eta^1 + \frac{d^2 \eta^2}{dx^2} + \right. \\
& \left. 2 \cotan \bar{\theta} \bar{\theta}' \frac{d\eta^2}{dx} + (\cotan \bar{\theta} \bar{\theta}'' - \bar{\theta}'^2 - \cos^2 \bar{\theta} \bar{\varphi}'^2) \right) \frac{\partial}{\partial \theta^2} \tag{43}
\end{aligned}$$

### The spectrum of small fluctuations around $K_1/K_1^*$ kinks

Plugging the  $K_1$  solutions into (43), we obtain the differential operator acting on the second-order fluctuation operator around the  $K_1/K_1^*$  kinks:

$$\Delta_{K_1} \eta = \left[ -\frac{d^2 \eta^1}{dx^2} + \left( \sigma^2 - \frac{2\sigma^2}{\cosh^2 \sigma x} \right) \eta^1 \right] \frac{\partial}{\partial \theta^1} + \left[ -\frac{d^2 \eta^2}{dx^2} + 2\sigma \tanh \sigma x \frac{d\eta^2}{dx} + \bar{\sigma}^2 \eta^2 \right] \frac{\partial}{\partial \theta^2} \tag{44}$$



Parallel transport along  $K_1$  kinks:

$$\nabla_{\theta'_{K_1}} v = 0$$

The vector fields  $v(x) = v^1(x)\frac{\partial}{\partial\theta^1} + v^2(x)\frac{\partial}{\partial\theta^2}$  parallel along the  $K_1$  kink satisfy:

$$\frac{dv^i}{dx} + \Gamma_{jk}^i \bar{\theta}'^j v^k = 0$$

$$\left\{ \begin{array}{l} \frac{dv^1}{dx} = 0 \\ \frac{dv^2}{dx} + \sigma \frac{\cotan(2\arctan e^{\sigma x})}{\cosh \sigma x} v^2 = 0 \end{array} \right. , \quad \begin{array}{l} v^1(x) = 1 \\ v^2(x) = \cosh \sigma x \end{array} .$$

Therefore,  $v_1 = \frac{\partial}{\partial\theta^1}$  ,  $v_2(x) = \cosh \sigma x \frac{\partial}{\partial\theta^2}$  is a frame  $\{v_1, v_2\}$  in  $\Gamma(T\mathbb{S}^2|_{K_1})$  parallel to the  $K_1$  kink in which (44) reads:

$$\Delta_{K_1} \eta = \Delta_{K_1^*} \eta = \left[ -\frac{d^2 \bar{\eta}^1}{dx^2} + \left( \sigma^2 - \frac{2\sigma^2}{\cosh^2 \sigma x} \right) \bar{\eta}^1 \right] v_1 + \left[ -\frac{d^2 \bar{\eta}^2}{dx^2} + \left( 1 - \frac{2\sigma^2}{\cosh^2 \sigma x} \right) \bar{\eta}^2 \right] v_2 \quad (45)$$

where  $\eta = \bar{\eta}^1 v_1 + \bar{\eta}^2 v_2$ ,  $\eta^1 = \bar{\eta}^1$ , and  $\eta^2 = \cosh \sigma x \bar{\eta}^2$ .

The second-order fluctuation operator is a diagonal matrix of transparent Pösch-Teller Schrödinger operators with very well known spectra.

In the  $v_1 = \frac{\partial}{\partial\theta^1}$  direction we find the Schrödinger operator governing sG kink fluctuations, as expected. But finding another Pösch-Teller potential of the same type in the  $v_2 = \frac{\partial}{\partial\theta^2}$  direction comes out as a surprise because there is no a priori reason for such a behavior in the orthogonal direction.

$v_1$  direction: There is a bound state of zero eigenvalue and a continuous family of positive eigenfunctions:

$$\begin{aligned}\bar{\eta}_0^1(x) &= \operatorname{sech} \sigma x \quad , \quad \varepsilon_0^{(1)} = 0 \\ \bar{\eta}_k^1(x) &= e^{ik\sigma x} (\tanh \sigma x - ik) \quad , \quad \varepsilon^{(1)}(k) = \sigma^2(k^2 + 1) .\end{aligned}$$

$v_2 = \cosh \sigma x \frac{\partial}{\partial\theta^2}$  direction: The spectrum is similar but the bound state corresponds to a positive eigenvalue:

$$\begin{aligned}\bar{\eta}_{1-\sigma^2}^2(x) &= \operatorname{sech} \sigma x \quad , \quad \varepsilon_{1-\sigma^2}^{(2)} = 1 - \sigma^2 > 0 \\ \bar{\eta}_k^2(x) &= e^{ik\sigma x} (\tanh \sigma x - ik) \quad , \quad \varepsilon^{(2)}(k) = \sigma^2 k^2 + 1 .\end{aligned}$$

Because there are no fluctuations of negative eigenvalue, the  $K_1/K_1^*$  kinks are stable.

A similar procedure shows that the K2 kink/antikink are unstable. For the NTK kinks case, it is a difficult task to solve the spectral problem of the second order fluctuation operator, but it is possible to construct an alternative way, computing the Jacobi Fields and their zeroes along the kink solutions, in order to prove that NTK kinks are also unstable. See References [1] and [2].

[1] A.Alonso Izquierdo, M.A.G.L. and J.Mateos Guilarte. *Phys. Rev. Lett.* **101**, 131602 (2008).

[2] A.Alonso Izquierdo, M.A.G.L. and J.Mateos Guilarte. *Phys. Rev.* **D79** 125003 (2009).

### 3 The nonlinear $\mathbb{S}^3$ - sigma model

$$V(\phi_1, \phi_2, \phi_3, \phi_4) = \frac{1}{2} (\alpha_1^2 \phi_1^2 + \alpha_2^2 \phi_2^2 + \alpha_3^2 \phi_3^2 + \alpha_4^2 \phi_4^2) \quad (46)$$

$$\alpha_1^2 > \alpha_2^2 > \alpha_3^2 > \alpha_4^2 \geq 0 \quad (47)$$

$$V_{\mathbb{S}^3}(\phi_1, \phi_2, \phi_3) = \frac{\lambda^2}{2} (\phi_1^2 + \sigma_2^2 \phi_2^2 + \sigma_3^2 \phi_3^2) + \text{const.} \quad (48)$$

$$\lambda = \sqrt{\alpha_1^2 - \alpha_4^2}, \quad \sigma_2^2 = \frac{\alpha_2^2 - \alpha_4^2}{\alpha_1^2 - \alpha_4^2}, \quad \sigma_3^2 = \frac{\alpha_3^2 - \alpha_4^2}{\alpha_1^2 - \alpha_4^2}, \quad 1 > \sigma_2^2 > \sigma_3^2 > 0$$

$$V_{\mathbb{S}^3} = \frac{1}{2} (\phi_1^2 + \sigma_2^2 \phi_2^2 + \sigma_3^2 \phi_3^2) \quad (49)$$

$$\mathcal{M} = \{v^+ \equiv (0, 0, 0, R), v^- \equiv (0, 0, 0, -R)\}$$

(“North” and “South” poles of  $\mathbb{S}^3$ ).

“Cutting”  $\mathbb{S}^3$  by the hyperplanes  $\phi_1 = 0$ ,  $\phi_2 = 0$ , or  $\phi_3 = 0$ , reduces the  $\mathbb{S}^3$ -model to three copies of the  $\mathbb{S}^2$ -model.

Note that the  $\phi_4 = 0$ -case is not relevant from the solitary waves point of view, because  $\mathcal{M}$  is not included in this situation.

There are three “singular” topological kinks and three families of “singular” non-topological kinks.

$\phi_2 = \phi_3 = 0 \Rightarrow K_1$  topological kink.

$\phi_1 = \phi_3 = 0 \Rightarrow K_2$  topological kink.

$\phi_1 = \phi_2 = 0 \Rightarrow K_3$  topological kink.

$\phi_1 = 0 \Rightarrow NTK_I$  family of non-topological kinks.

$\phi_2 = 0 \Rightarrow NTK_{II}$  family of non-topological kinks.

$\phi_3 = 0 \Rightarrow NTK_{III}$  family of non-topological kinks.

To calculate the generic solutions we use the following version of conical coordinates in  $\mathbb{R}^4$

$$\phi_1^2 = u_0 \frac{u_1 u_2 u_3}{\bar{\sigma}_2^2 \bar{\sigma}_3^2} \tag{50}$$

$$\phi_2^2 = u_0 \frac{(\bar{\sigma}_2^2 - u_1)(\bar{\sigma}_2^2 - u_2)(\bar{\sigma}_2^2 - u_3)}{\sigma_2^2 \bar{\sigma}_2^2 (\bar{\sigma}_3^2 - \bar{\sigma}_2^2)} \quad (51)$$

$$\phi_3^2 = u_0 \frac{(\bar{\sigma}_3^2 - u_1)(\bar{\sigma}_3^2 - u_2)(\bar{\sigma}_3^2 - u_3)}{\sigma_3^2 \bar{\sigma}_3^2 (\bar{\sigma}_2^2 - \bar{\sigma}_3^2)} \quad (52)$$

$$\phi_4^2 = u_0 \frac{(1 - u_1)(1 - u_2)(1 - u_3)}{\sigma_2^2 \sigma_3^2} \quad (53)$$

with:

$$0 < u_1 < \bar{\sigma}_2^2 < u_2 < \bar{\sigma}_3^2 < u_3 < 1$$

These inequalities define the interior of the parallelepiped  $\mathbb{P}_3$ .

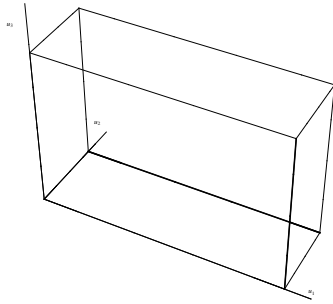

$\mathbb{P}_3$  - Parallelepiped. Bold lines denote the regions with  $u_1 = u_2$  and  $u_2 = u_3$ .

Constraint-equation for  $\mathbb{S}^3$  reduces to:

$$u_0 = R^2$$

$\mathcal{M}$ :

$$v^\pm \equiv (u_1, u_2, u_3) = (0, \bar{\sigma}_2^2, \bar{\sigma}_3^2)$$

(only a point in  $\mathbb{P}_3$ ).

$$V_{\mathbb{S}^3}(u_1, u_2, u_3) = -\frac{u_0}{2} (u_1 + u_2 + u_3 - \bar{\sigma}_2^2 - \bar{\sigma}_3^2) \quad (54)$$

$$V_{\mathbb{S}^3}(u_1, u_2, u_3) = -\frac{u_0}{2} \left( \frac{u_1 (u_1 - \bar{\sigma}_2^2)(u_1 - \bar{\sigma}_3^2)}{(u_1 - u_2)(u_1 - u_3)} + \frac{u_2 (u_2 - \bar{\sigma}_2^2)(u_2 - \bar{\sigma}_3^2)}{(u_2 - u_1)(u_2 - u_3)} + \frac{u_3 (u_3 - \bar{\sigma}_2^2)(u_3 - \bar{\sigma}_3^2)}{(u_3 - u_1)(u_3 - u_2)} \right) \quad (55)$$

Energy functional for static configurations:

$$E[u_1, u_2, u_3] = \lambda \int dx \left\{ \frac{1}{2} \sum_{j=1}^3 g_{jj} \left( \frac{du_j}{dx} \right)^2 + \frac{u_0}{2} \sum_{j=1}^3 \frac{u_j (u_j - \bar{\sigma}_2^2)(u_j - \bar{\sigma}_3^2)}{U'(u_j)} \right\} \quad (56)$$

with:

$$U(u) = (u - u_1)(u - u_2)(u - u_3)$$

$$g_{11} = \frac{-u_0}{4} \frac{(u_1 - u_2)(u_1 - u_3)}{u_1(u_1 - \bar{\sigma}_2^2)(u_1 - \bar{\sigma}_3^2)(u_1 - 1)}$$

$$g_{22} = \frac{-u_0}{4} \frac{(u_2 - u_1)(u_2 - u_3)}{u_2(u_2 - \bar{\sigma}_2^2)(u_2 - \bar{\sigma}_3^2)(u_2 - 1)}$$

$$g_{33} = \frac{-u_0}{4} \frac{(u_3 - u_1)(u_3 - u_2)}{u_3(u_3 - \bar{\sigma}_2^2)(u_3 - \bar{\sigma}_3^2)(u_3 - 1)}$$

Bogomol'nyi form:

$$E[u_1, u_2, u_3] = \lambda \int \frac{dx}{2} \left\{ \sum_{i=1}^3 g_{ii} \left( \frac{du_i}{dx} + g^{ii} \frac{\partial W}{\partial u_i} \right)^2 \right\} + \lambda \int dx \sum_{j=1}^3 \frac{\partial W}{\partial u_j} \frac{du_j}{dx} \quad (57)$$



$$\frac{u_0}{2} \sum_{j=1}^3 \frac{u_j (u_j - \bar{\sigma}_2^2)(u_j - \bar{\sigma}_3^2)}{U'(u_j)} = \frac{1}{2} \sum_{j=1}^3 g^{jj} \left( \frac{\partial W}{\partial u_j} \right)^2 \quad (58)$$

$$W(u_1, u_2, u_3) = W_1(u_1) + W_2(u_2) + W_3(u_3)$$

$$W(u_1, u_2, u_3) = u_0 \left( (-1)^{a_1} \sqrt{1 - u_1} + (-1)^{a_2} \sqrt{1 - u_2} + (-1)^{a_3} \sqrt{1 - u_3} \right) \quad (59)$$

$$a_1, a_2, a_3 = 0, 1.$$

Bogomol'nyi arrangement lead to First Order equations :

$$\frac{du_1}{dx} = g^{11} \frac{\partial W}{\partial u_1}, \quad \frac{du_2}{dx} = g^{22} \frac{\partial W}{\partial u_2}, \quad \frac{du_3}{dx} = g^{33} \frac{\partial W}{\partial u_3} \quad (60)$$

$$\begin{aligned} \frac{du_1}{dx} &= (-1)^{a_1} \frac{2u_1(u_1 - \bar{\sigma}_2^2)(u_1 - \bar{\sigma}_3^2)\sqrt{1 - u_1}}{U'(u_1)} \\ \frac{du_2}{dx} &= (-1)^{a_2} \frac{2u_2(u_2 - \bar{\sigma}_2^2)(u_2 - \bar{\sigma}_3^2)\sqrt{1 - u_2}}{U'(u_2)} \\ \frac{du_3}{dx} &= (-1)^{a_3} \frac{2u_3(u_3 - \bar{\sigma}_2^2)(u_3 - \bar{\sigma}_3^2)\sqrt{1 - u_3}}{U'(u_3)} \end{aligned} \quad (61)$$

Or, in differential form:

$$\frac{dx}{U'(u_j)} = \frac{(-1)^{a_j} du_j}{2u_j(u_j - \bar{\sigma}_2^2)(u_j - \bar{\sigma}_3^2) \sqrt{1 - u_j}}, \quad j = 1, 2, 3 \quad (62)$$

These quadratures can be easily converted to rational ones introducing the variables:

$$s_1 = (-1)^{a_1} \sqrt{1 - u_1}, \quad s_2 = (-1)^{a_2} \sqrt{1 - u_2}, \quad s_3 = (-1)^{a_3} \sqrt{1 - u_3}$$

$$\sum_{j=1}^3 \frac{ds_j}{1 - s_j^2} = -dx \quad (63)$$

$$\sum_{j=1}^3 \frac{ds_j}{\sigma_2^2 - s_j^2} = -dx \quad (64)$$

$$\sum_{j=1}^3 \frac{ds_j}{\sigma_3^2 - s_j^2} = -dx \quad (65)$$

$$\operatorname{arctanh} s_1 + \operatorname{arctanh} s_1 + \operatorname{arctanh} s_1 = -x - \gamma_0 \quad (66)$$

$$\operatorname{arccoth} \frac{s_1}{\sigma_2} + \operatorname{arctanh} \frac{s_2}{\sigma_2} + \operatorname{arctanh} \frac{s_3}{\sigma_2} = -\sigma_2 (x + \gamma_2) \quad (67)$$

$$\operatorname{arccoth} \frac{s_1}{\sigma_3} + \operatorname{arccoth} \frac{s_2}{\sigma_3} + \operatorname{arctanh} \frac{s_3}{\sigma_3} = -\sigma_3 (x + \gamma_3) \quad (68)$$

Using addition formulas for hyperbolic functions, and defining “Vieta variables”:

$$A = s_1 + s_2 + s_3 \quad (69)$$

$$B = s_1 s_2 + s_1 s_3 + s_2 s_3 \quad (70)$$

$$C = s_1 s_2 s_3 \quad (71)$$

the equations reduce to a linear system:

$$\left. \begin{aligned} A - t_1 B + C &= t_1 \\ \sigma_2^2 t_2 A - \sigma_2 B + t_2 C &= \sigma_2^3 \\ \sigma_3^2 A - \sigma_3 t_3 B + C &= \sigma_3^3 t_3 \end{aligned} \right\} \quad (72)$$

$$t_1 = \tanh(-(x + \gamma_0)), \quad t_1 = \tanh(-(x + \gamma_2)), \quad t_1 = \tanh(-(x + \gamma_3))$$

$$z^3 - Az^2 + Bz - C = 0 \tag{73}$$

Three-parameter family of Topological Kinks

$$u_1(x) = 1 - \left( \frac{A}{3} + 2\sqrt{-q} \cos \frac{\theta}{3} \right)^2 \tag{74}$$

$$u_2(x) = 1 - \left( \frac{A}{3} + \sqrt{-q} \left( -\cos \frac{\theta}{3} - \sqrt{3} \sin \frac{\theta}{3} \right) \right)^2 \tag{75}$$

$$u_3(x) = 1 - \left( \frac{A}{3} + \sqrt{-q} \left( -\cos \frac{\theta}{3} + \sqrt{3} \sin \frac{\theta}{3} \right) \right)^2 \tag{76}$$

$$q = \frac{1}{3}B - \frac{1}{9}(-A)^2, \quad r = \frac{1}{6}(B(-A) - 3(-C)) - \frac{1}{27}(-A)^3, \quad \theta = \arccos \frac{-r}{\sqrt{-q^3}}$$

Thank you very much

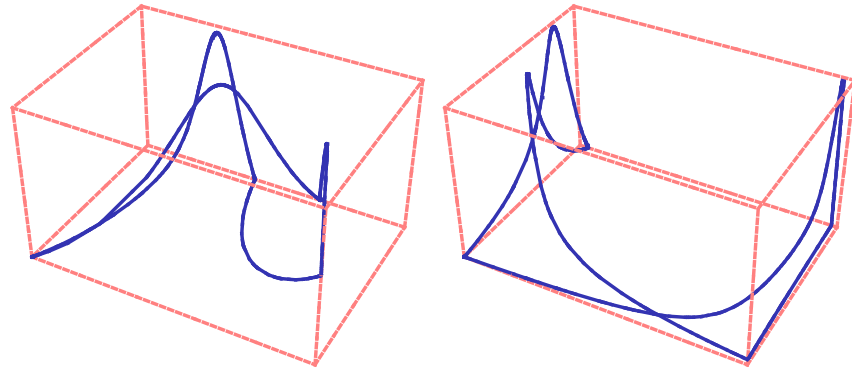

Two kink orbits.

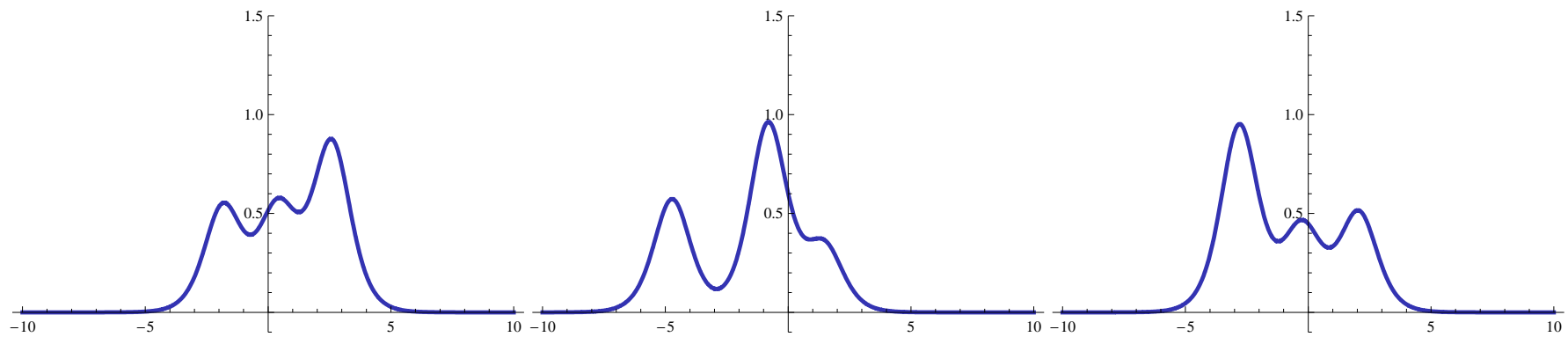

Kink energy density for different values of the constants.